

<完成写真>

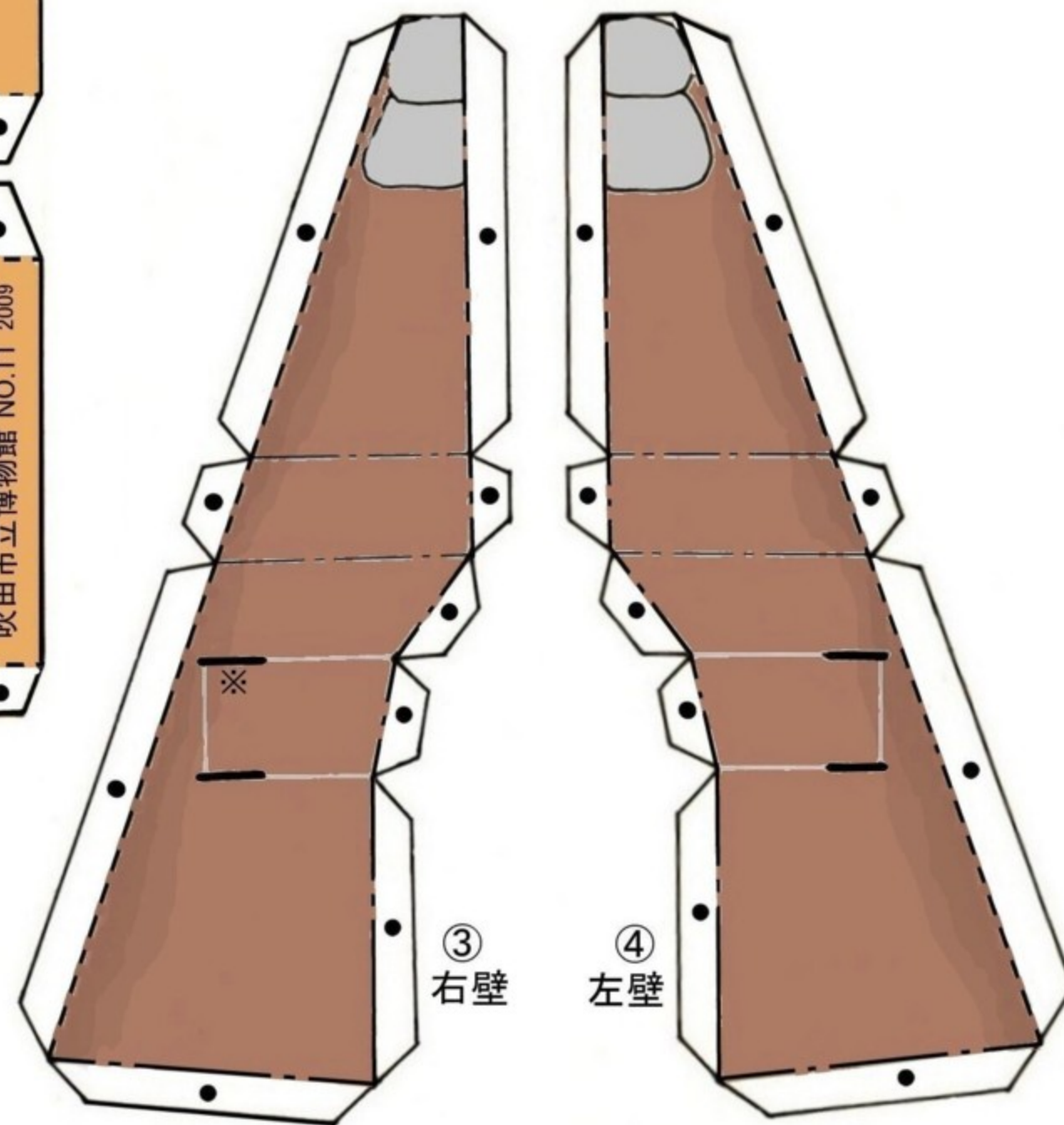

- (太線) 切りこみ ● のりづけ
- 山折り ○ うらのりづけ
- - - - 谷折り ▲ きりぬき

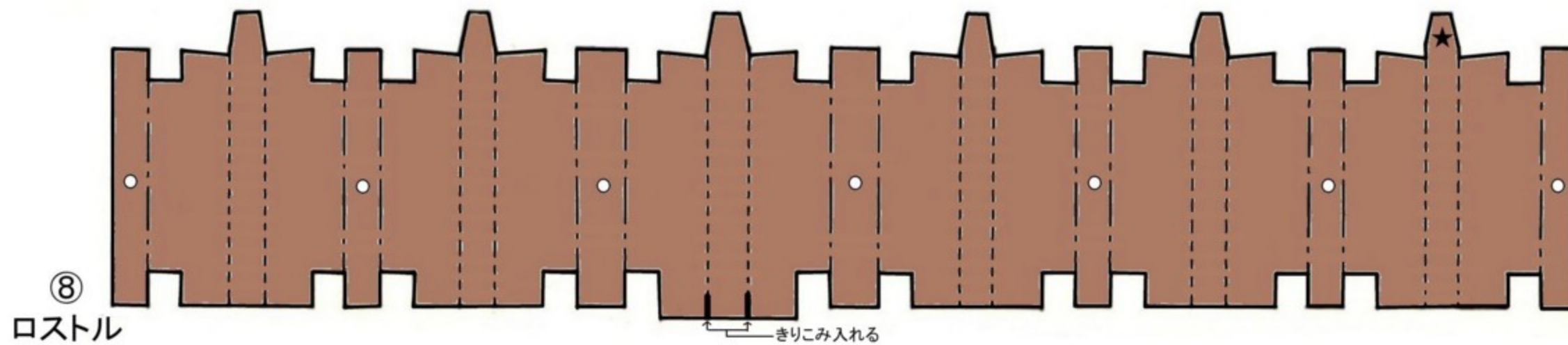
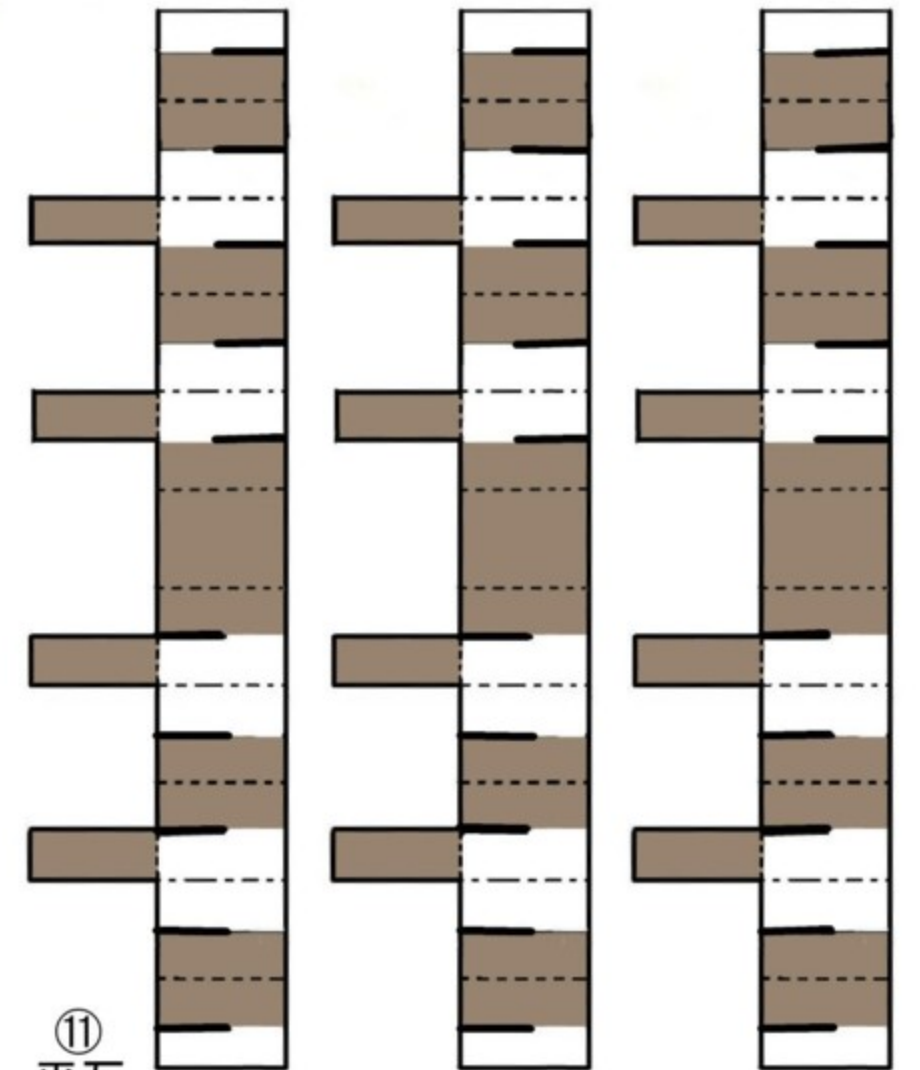
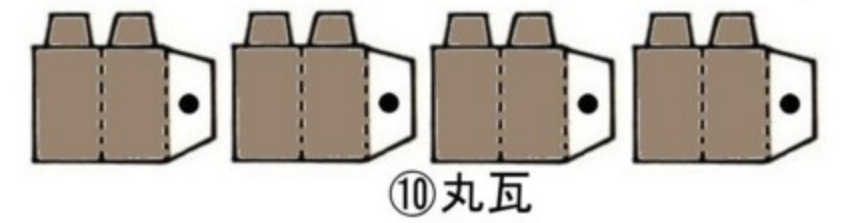
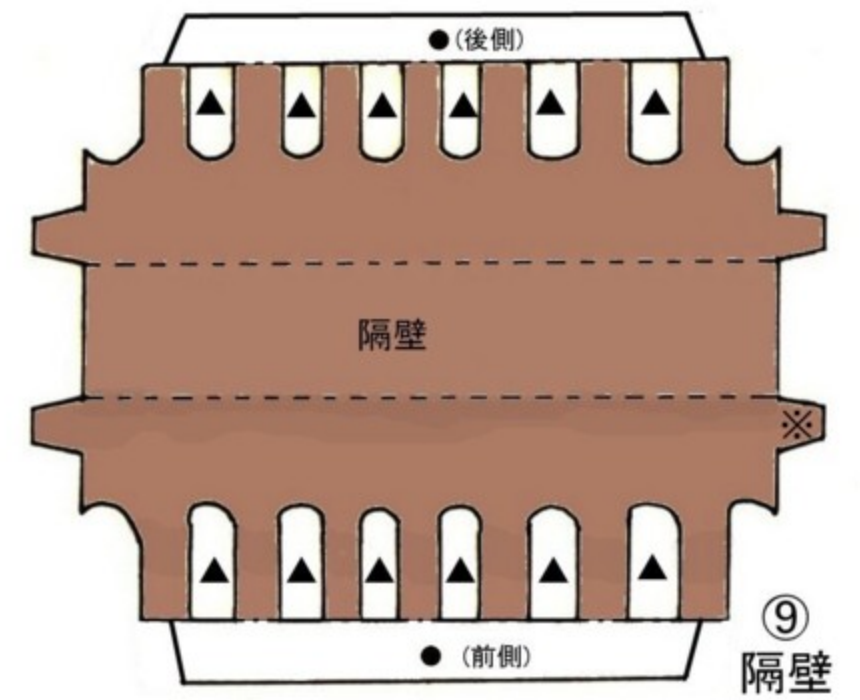
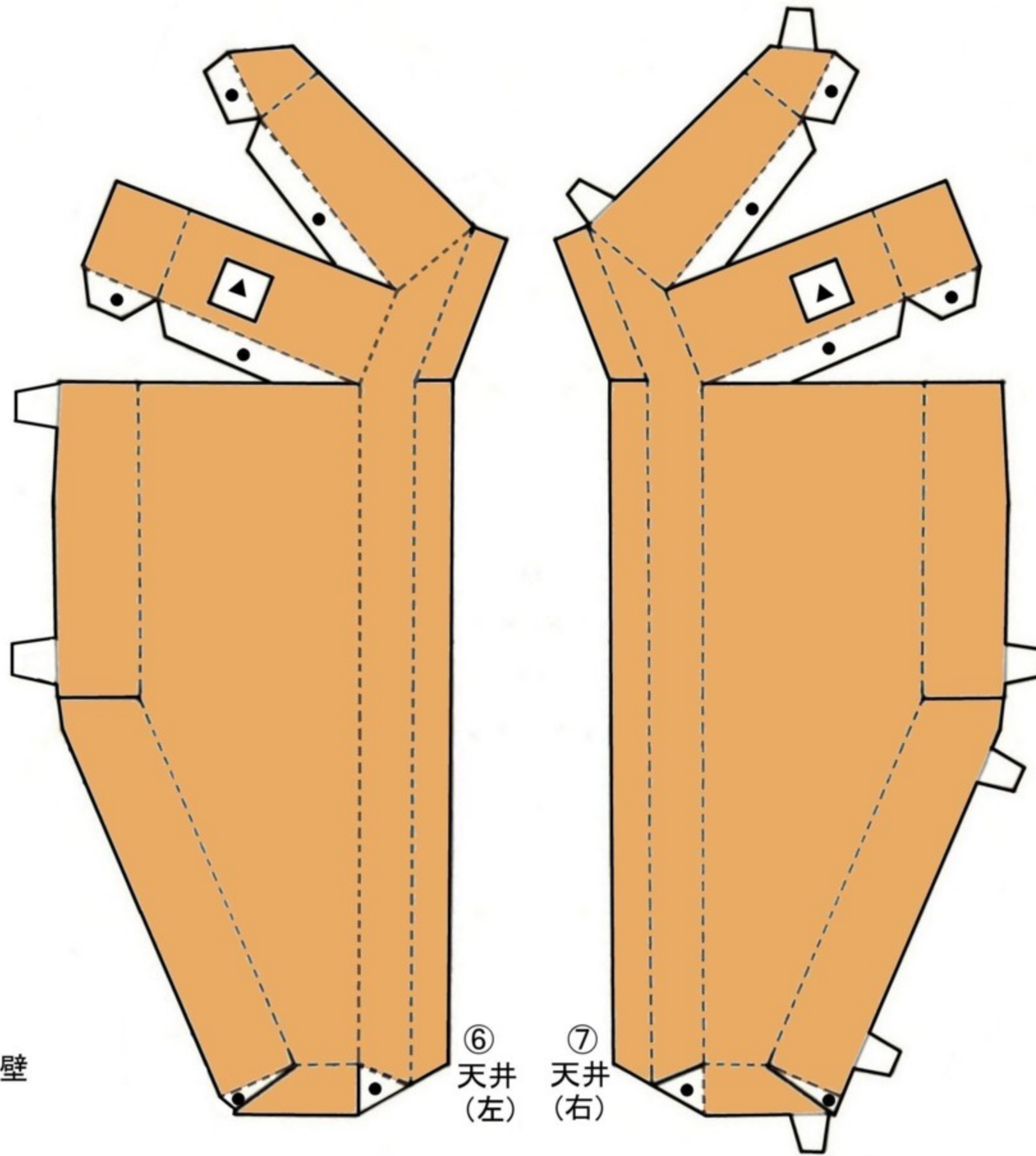
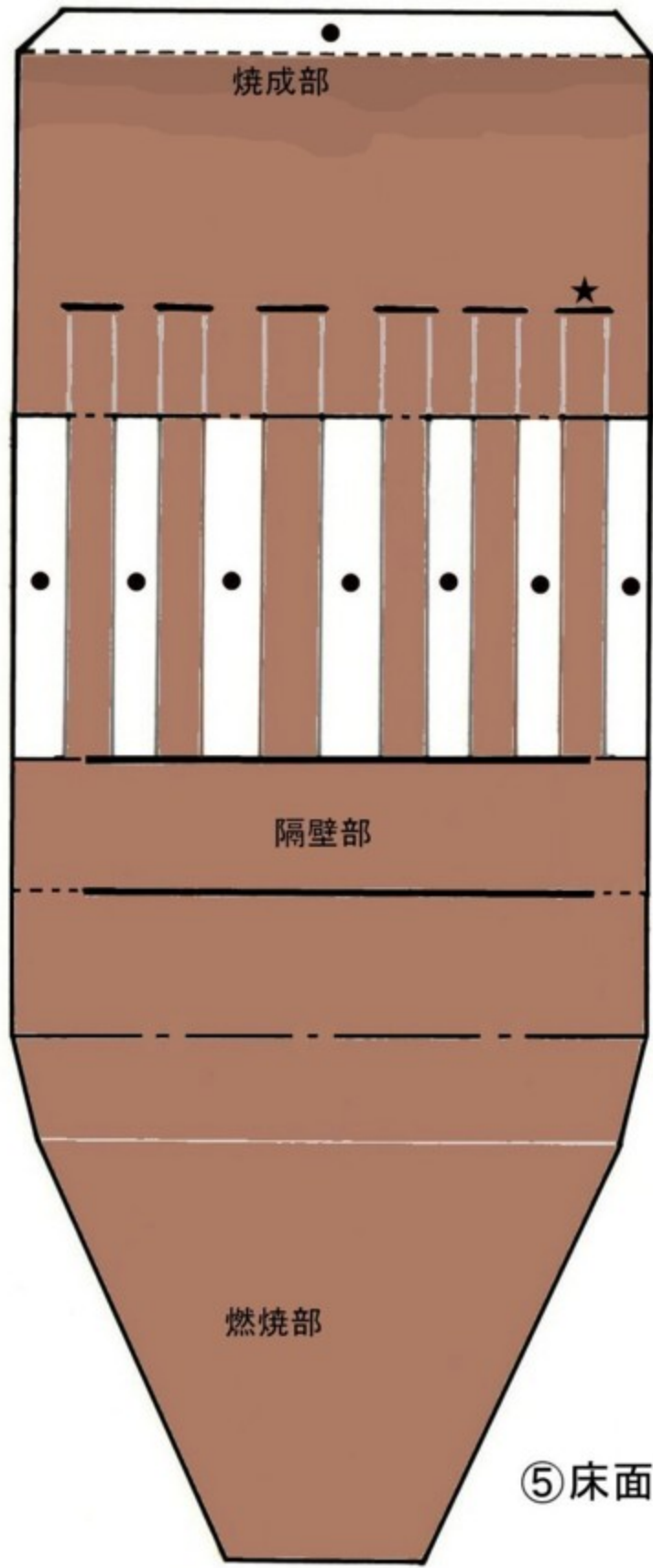

<1 各部品を作る>

* 各部品にきりこみを入れてからきりぬく。

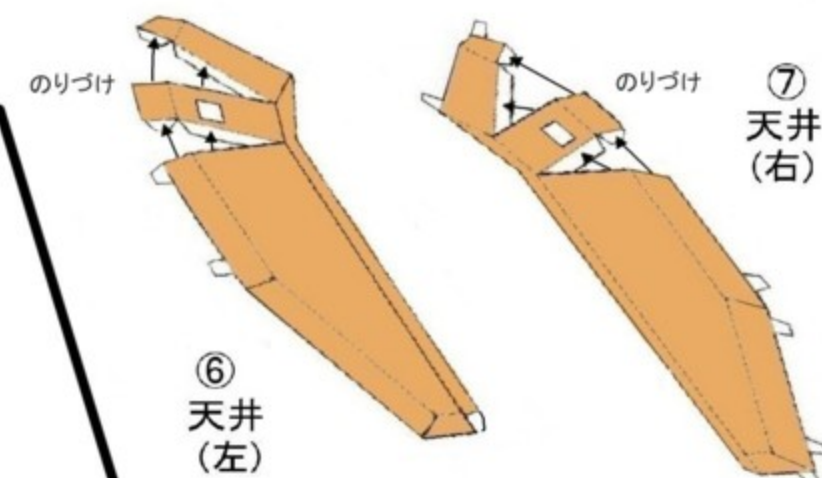
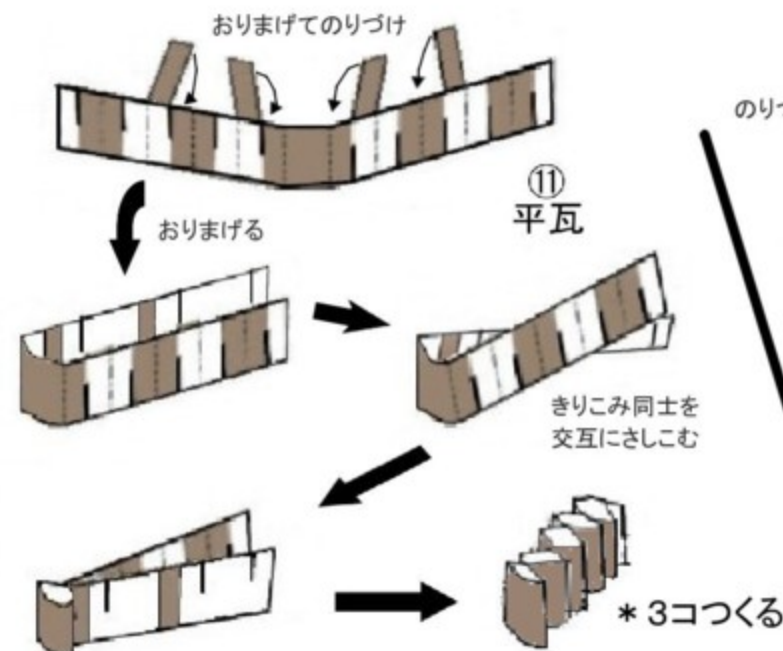
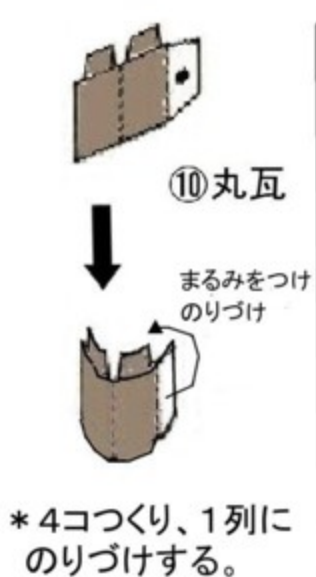
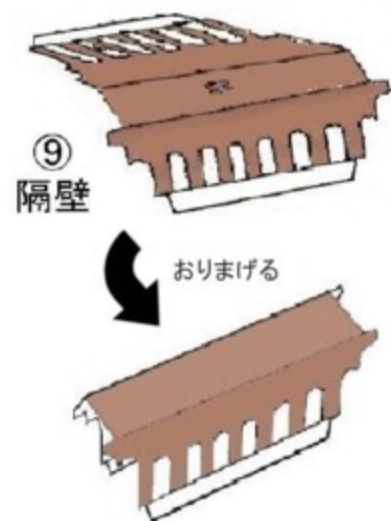
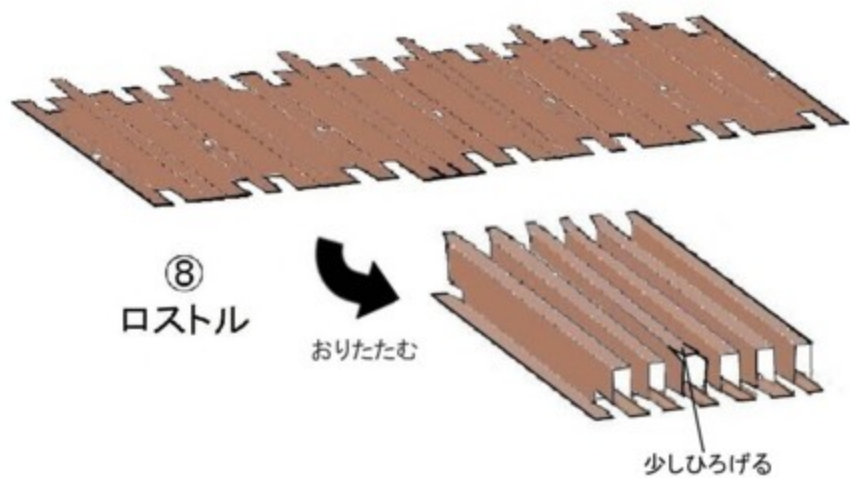

<2 部品を組み立てる>

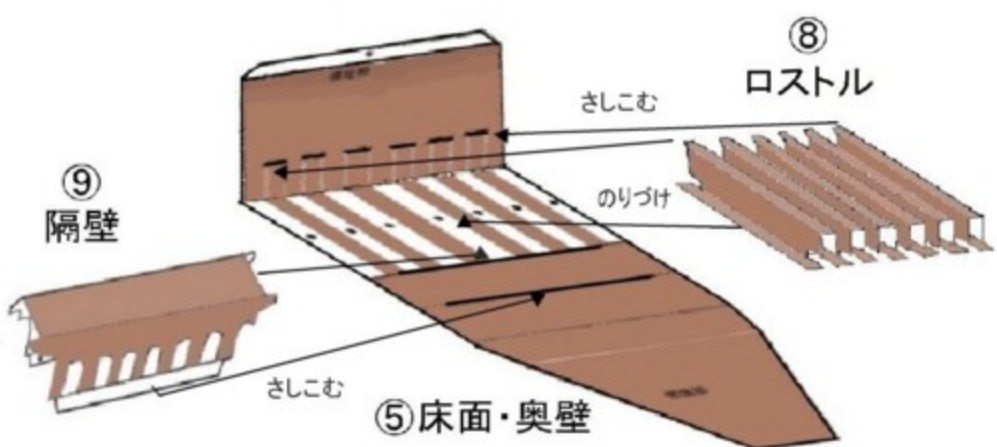

⑤床面・奥壁に⑧ロストルをさしこみ、のりづけする。
⑨隔壁をさしこむ。

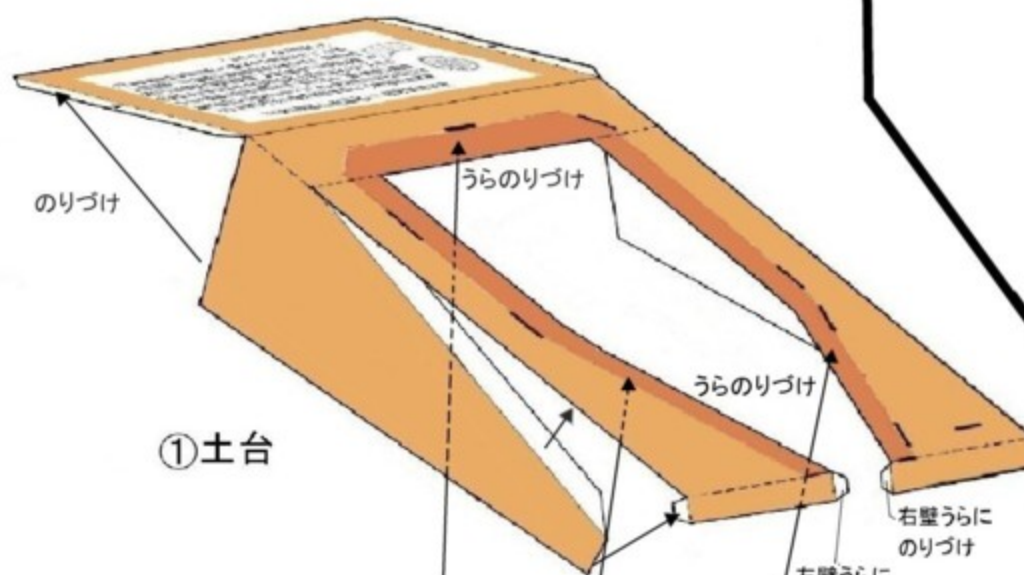

①土台

①土台を組み立てる。
⑤床面・奥壁を①土台にのりづけする。

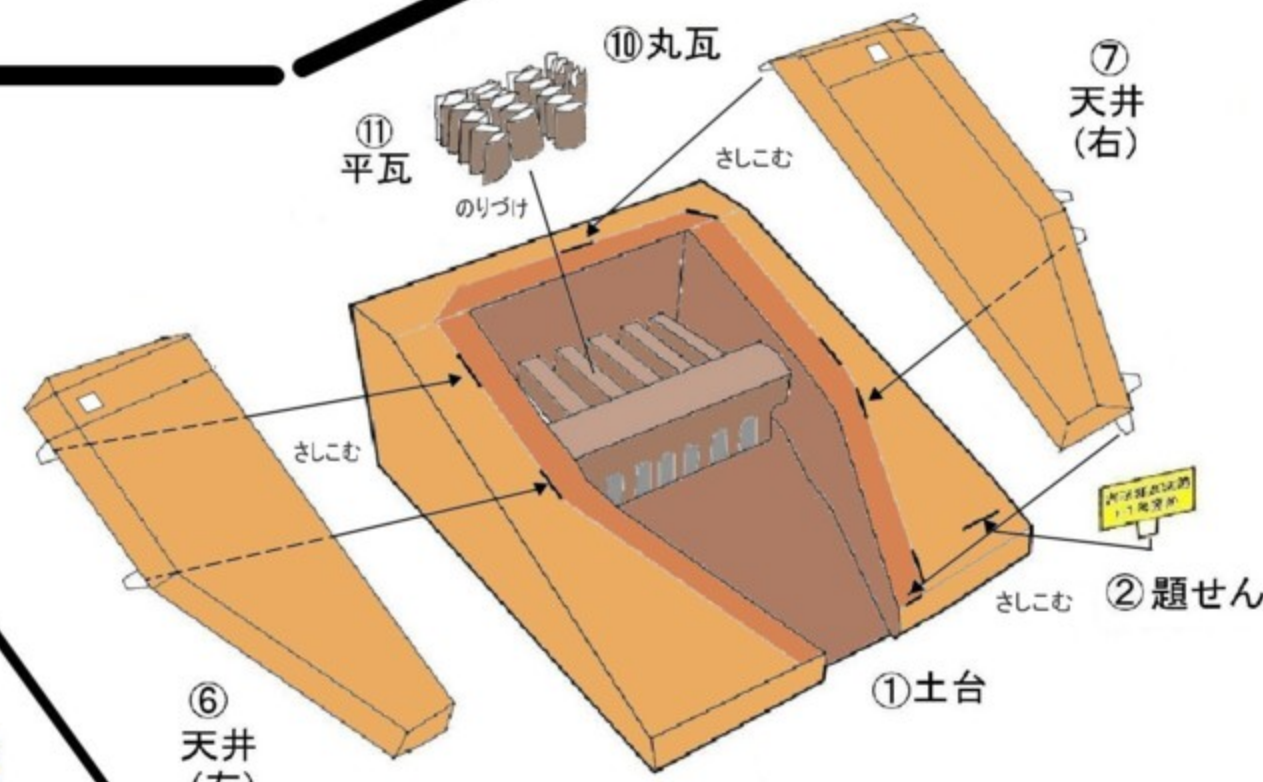

①土台に⑩丸瓦と⑪平瓦をのりづけする。
⑥天井と⑦天井、②題せんをさしこんで完成。

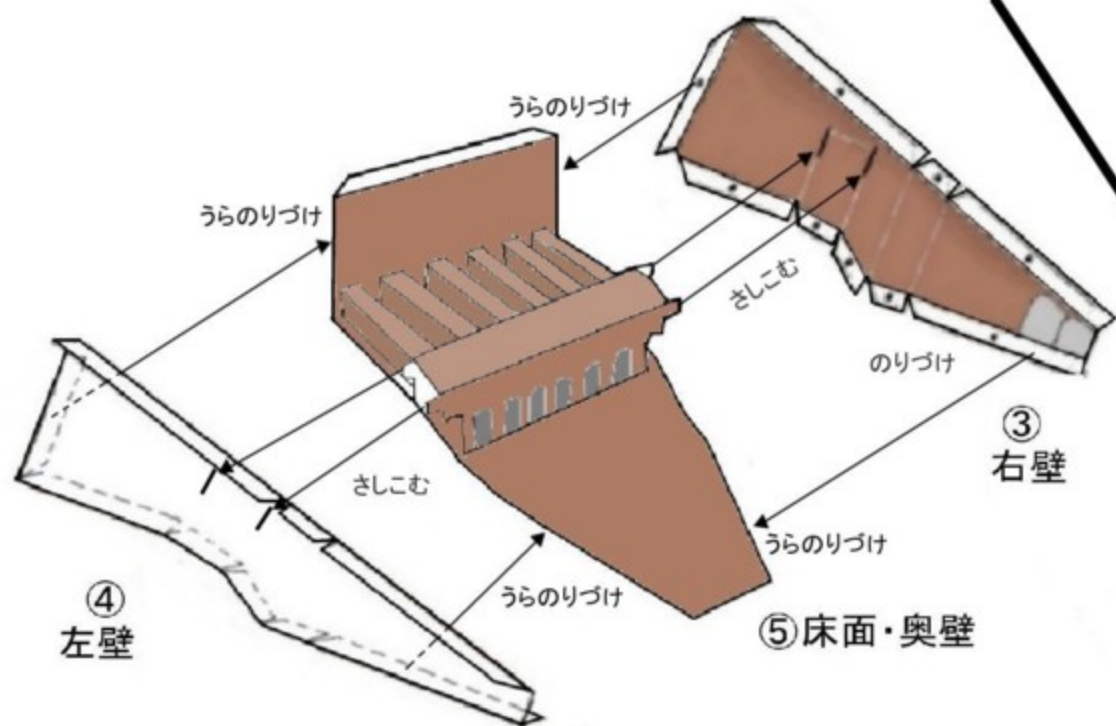

⑤床面・奥壁に③右壁と④左壁をさしこみ、のりづけする。

<組み立て完成図>

